

RR110 Ultra Low Power 'Wake Up'

Summary

The CotoMOS® CS128 is a surface mount, solid state, optically isolated relay that is specified to have a maximum load current of 4.5 A and a maximum on-resistance of 0.05 Ω when used in AC mode. A question that frequently arises is whether this type of relay can be used in parallel to increase the current-carrying capacity of the relay. (Stacking relays to increase switching voltage is feasible and discussed in the CotoMOS® product literature.) The results show it is feasible to switch up to 25 A though a bank of six parallel relays. Coto has developed an empirical formula that can be used to estimate the equilibrium temperature reached by the relays based on these factors: the ambient temperature, the duty cycle of the switched current, the frequency, the total current through the relay bank, and the number of relays in parallel. The calculator is accurate to 95%. The combined benefit of the reduced resistance of a parallel array of CS128's and the division of current between them means an array of six can switch 36X the power of a single relay!

Background

The specified ampacity of a single CS128 device is 4.5 A. It therefore seems intuitive that multiple relays used in parallel should increase the current switching capacity in proportion to the number used; in other words, 6 relays (for example) should be able to switch $6 \times 4.5 \text{ A} = 27 \text{ A}$. In addition, the current switching capacity is doubled in the DC mode, so that the current carrying capacity of 6 relays should in theory be $2 \times 6 \times 4.5 = 54 \text{ A}$. However, parallel operation has to take into account that the turn-on time of the CS128 can vary appreciably from one device to another; preliminary timing tests on a sample of six relays showed a mean of 585 μs with a standard deviation of 65 μs using a 20 mA LED square wave drive current. The potential therefore exists for the fastest relays to take a higher inrush current than the slower ones when used in parallel to switch an alternating current input. This in turn would be expected to cause the faster relays to run hotter. Coto therefore conducted tests to determine the magnitude of this effect and whether it would prevent CS128 relays from

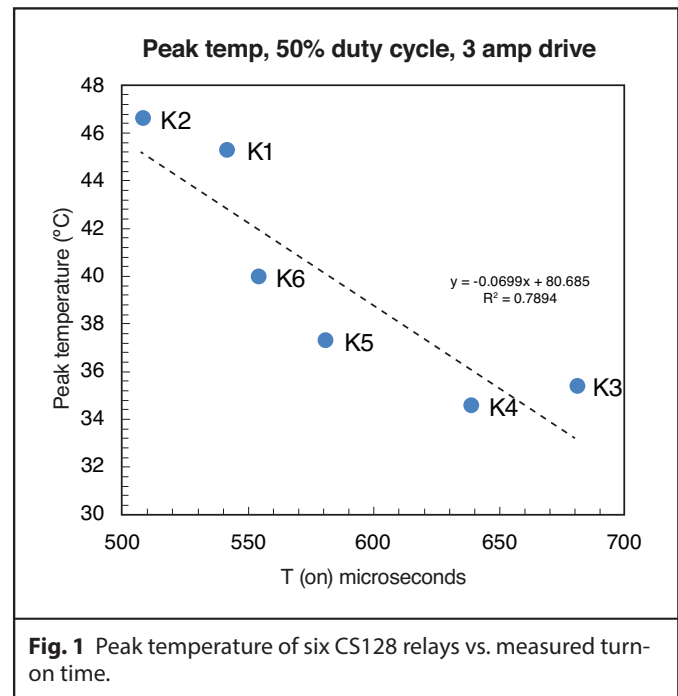

being used in parallel. Fig. 1 shows the peak temperatures of six relays switching a 3 A square wave. Clearly the faster relays ran hotter than the slow ones by about 10 °C.

Experimental Design

Based on the temperature vs. timing results, we hypothesized that the peak temperatures reached by each relay in a bank of relays would depend on the following factors:

1. Turn-on times for each relay
2. Ambient temperature
3. Duty cycle of the current being switched
4. Frequency of the current being switched
5. Presence or absence of forced cooling
6. Total current through the bank of relays
7. Number of relays in parallel.

A more elaborate test would equalize the turn-on times for each relay by adjusting the individual LED drive currents. However, we felt that this would not be practical in most of our customers' applications, so instead, we simply averaged the temperatures of the relays. Also to simplify the testing, the tests were only run while switching a rectangular pulse or square wave current, or DC (static) currents.

The tests were run in a factorial manner, varying the duty cycle of the current from 10 to 100% (100% being DC), the frequency from 0.1 Hz to 100 Hz, the current from 1 A to 20 A, and the number of relays in parallel from 2 to 6. Presence or absence of forced air cooling was modeled as a categorical variable. Ambient temperature was also recorded.

Test Method

The CS128 was used in AC mode for the tests. (See Fig. 1 in the CS128 product data sheet.) Power was fed from a Kepco 30V 20A variable power supply, through a bank of up to 6 parallel CS128 devices, and was dissipated in a 1 Ω, 1500 W air-cooled resistor. The relay LED's were turned on using an SCR-buffered HP 8116 pulse generator using a drive current of 20 mA per relay. The temperatures of the relays were monitored with an Omega multi-channel data logger and Type K thermocouples mounted with Kapton tape to the top of the relays. The relays were either cooled with a small PC ventilator fan or run in static air, with no heat sinking. The air flow velocity parallel to the top surface of the CS128 packages was approximately 0.8 m.s⁻¹

Analysis of Results

Peak temperature data was recorded for each relay while varying and recording the values of the following factors: total current through the array, I_{tot} ; the frequency of the current, f , in Hz; the duty cycle d , expressed as a percentage; the number of relays in parallel, n ; and the presence or absence of forced air cooling.

The average peak temperatures of the relays in the bank were fitted to these variables using multiple regression, resulting in a model with an R-squared value of 95.3% (in other words, the model is 95% accurate over the range of input variables.)

Analyzing the lab test data results in this simple empirical formula for estimating Δt , the expected average relay temperature rise above ambient:

$$\Delta t = \frac{I_{tot}^{1.1} f^{0.1} \sqrt[3]{d}}{K n^{0.8}}$$

where I_{tot} , f , d and n are the parameters described previously, and K is a factor depending on the presence of active cooling (2.05) or no cooling (0.65). To obtain the best model accuracy, the parameter values should be limited to: $1 < I_{tot} < 30$ A, $0.01 < f < 100$ Hz (use 0.01 for DC), $10 < d < 100\%$, and $1 < n < 6$. Note that at frequencies above 100 Hz, overheating of the fastest relays can occur during parallel operation, for the reasons described previously.

It is simple to build this formula into a spreadsheet such as Microsoft Excel to estimate Δt . Then, knowing the ambient temperature T_{amb} , the expected maximum temperature of the relays can be estimated as $(T_{amb} + \Delta t)$. If this number exceeds 85 °C (the maximum recommended operating temperature of the CS128,) steps can be taken to increase the ampacity of the relay bank by adding more relays. For example, consider a proposed set-up of 4 parallel CS128's carrying a rectangular 60 Hz current peaking at 15 A with a duty cycle of 40% and no active cooling. The equation predicts a temperature rise of 51 °C above ambient, which could take the relays close to the operational temperature limit of 85 °C. Better in this case to use six parallel relays (predicted $\Delta t = 37$ °C,) or add some active cooling.

Circuit Configuration

The circuit configuration for an example of a parallel bank of four relays is shown in Figure 2. Select the values of the current-limiting resistors R_1, R_2, \dots, R_n to supply 20 mA control current to the relays' LED control inputs, using the formula:

$$R_{in} = \frac{(V_{CC} - V_F)}{I_F}$$

where V_{cc} is the driver supply voltage, I_F is the LED drive current per relay and V_F is the forward voltage drop of the relay's LED. Assume V_F is 1.4V. If the load shown in Figure 2 is significantly inductive, extra MOSFET output circuit protection devices such as clamping diodes, Zener diodes, MOV's or transient voltage suppressors may be required to protect the CS128 devices.

Their use is beyond the scope of this document but can be reviewed at this link:

<http://cotorelay.com/wp-content/uploads/2014/05/Coto-MOS-TechAppInfo.pdf>

Conclusions

1. The CotoMOS® CS128 relay can be used in parallel, in AC mode, to switch higher load currents than are switchable using a single relay.
2. Faster (lower turn-on time) relays run about 10 °C hotter than slow ones when switching AC load currents.
3. The load currents can be hot-switched.
4. The relays to be used can be selected randomly from stock. No sorting of relay turn-on times is required.
5. Balancing turn-on times by adjusting individual relay LED currents is not required.
6. Only rectangular or square wave load currents have been tested so far.
7. Relay heating increases with the frequency of the load current, and only frequencies up to 100 Hz have been tested so far.
8. Forced air cooling reduces peak temperatures by about 20 °C (Passive heat sinks have not been tested yet.)
9. An empirical formula has been developed to estimate peak relay temperatures for different load conditions.

For further information, contact **CotoMOS@cotorelay.com**

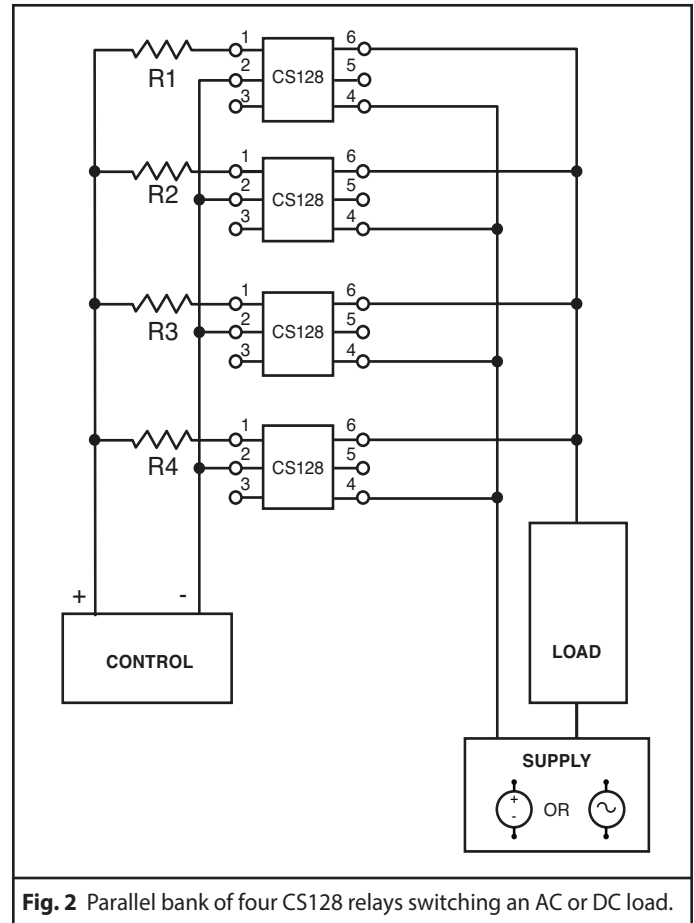

Fig. 2 Parallel bank of four CS128 relays switching an AC or DC load.