

D8000 SERIES USB INTERFACE MODULES



D8000 FEATURES

- Complete data acquisition systems.
- Analog and Digital I/O models available.
- USB interface.
- Modbus RTU Protocol.
- Up to 25 conversions per second.
- 500Vrms analog input or analog output isolation.
- 16-bit analog input measurement resolution.
- Continuous self-calibration; no adjustments required.
- Programmable analog input digital filters.
- Requires +10V to +30Vdc unregulated supply.
- Removable screw terminal plug.

APPLICATIONS

- Process monitoring and control
- Data logging to any host computer
- Product testing

GENERAL DESCRIPTION

The D8000 series USB interface modules are a family of complete data acquisition modules for use in process control systems. The analog input models can measure process signals such as thermocouples, 4-20mA current loops, and discrete contact closures. The analog output models can generate voltage or current signals for controlling annunciators or valves. The digital input and output models can sense the state of remote digital signals or control solid state relays. Complete data acquisition systems can be created with ease with the D8000 modules and a host computer.

The modules provide direct connection to a wide variety of sensors and annunciators such as thermocouple probes, 4-20mA loops, and DC. They perform all signal conditioning, linearization and contain no internal pots or DIP switches. All user-selectable features such as ranges, communications settings are stored in nonvolatile EEPROM, which maintains these values even after power is removed.

D8000 SPECIFICATIONS (typical at +25°C and nominal power supply unless otherwise noted)

General

- Programmable digital filters in analog input modules.
- Max CMV, input to output at 115Vrms, 60hz: 500V rms.
- All setups stored in EEPROM.
- Software disable unused analog input channels.

Interface

- Communications via Modbus RTU protocol.
- Interface via USB port.

Power Requirements

- Unregulated +10V to +30Vdc.
- Protected against power supply reversals.

Environmental

- Temperature Range: Operating -25°C to +70°C.
- Storage: -25°C to +85°C.
- Relative Humidity: 0 to 95% non-condensing.

Warranty

- 12 months on workmanship and material.

Package, Dimensions and Connectors

- Case: ABS thermoplastic, UL-94-5VA rated.
- Dimensions: 6"x4"x1.5", mounting holes 6.5" on center.
- Connectors: Screw terminal barrier plug (supplied).
- Replace plug with LMI Components 04238 Series.

MODULE SPECIFICATIONS

D8100 Voltage Inputs

- Seven differential voltage inputs.
- Ranges: +/- .025V, +/- .05V, +/- .1V, ±1V, ±5V, ±10V.
- 16-bit ADC, 25/20 conversions per second.
- Accuracy: ±0.05% of FS max.
- Span Tempco: ±50ppm/°C max.
- Input burnout protection to 250 Vac.
- Input impedance: 20MΩ min.
- Power requirements: Serial = 1.4W.

D8200 Current Inputs

- Seven differential current inputs.
- Range: +/-20mA.
- 16-bit ADC, 25/20 conversions per second.
- Accuracy: ±0.05% of FS max.
- Span Tempco: ±50ppm/°C max.
- Voltage drop: 2.0V max.
- Input Impedance: <100 Ohms (70 typical).
- Power requirements: Serial = 1.4W.

D8300 Thermocouple Inputs

- Seven differential thermocouple inputs.
- Thermocouple types: J, K, T, E, R, S, B, and C.
- Ranges:

| | |
|-----------------|--------------|
| J = -200–760°C | R = 0–1750°C |
| K = -150–1250°C | S = 0–1750°C |
| T = -200–400°C | B = 0–1820°C |
| E = -100–1000°C | C = 0–2315°C |
- Thermocouple Accuracy (error from all sources) from 0-40°C ambient:

| |
|---|
| J, K, T, E = ±1.5°C max. |
| R, S, B, C = ±3.5°C max (300°C to +F.S.). |
- 16-bit ADC, 25/20 conversions per second.
- Input impedance: 20MΩ min.
- Automatic cold junction compensation.
- Lead resistance effect: <40μV per 350Ω.
- Open thermocouple and over range indication.
- Input burnout protection to 250Vac.
- Power requirements: Serial = 1.4W.

D8400 Voltage, Thermocouple, Current Inputs

- Seven Differential voltage, thermocouple, current inputs.
- Specifications equal to D8100, D8200 and D8300 series.

D8500 Analog Outputs

- Two analog outputs.
- Programmable voltage or current ranges.
- Voltage Ranges: 0-10Vdc, +/-10Vdc.
- Current Ranges: 0-20mA, 4-20mA.
- 250 conversions per second.
- Accuracy: +/-0.1%
- 12-bit DAC resolution.
- Span Tempco: ±25ppm/°C max.
- Settling Time to 0.1% FS: 1mS.
- Communications Watchdog Timer.
- Current Output Compliance: +/-12Vdc.
- Voltage Output Drive: 5mA max.
- 8-bit ADC Analog output signal readback.
- Isolation 500Vac, output common to system ground.
- Current output burnout protected to 250Vac.
- Power requirements: Serial = 2.1W.

D8710 Digital Inputs

- 15 Digital Inputs.
- Internal 10K pull-up resistors on each bit.
- Accept direct switch closure.
- Logic "0" = <1Vdc, Logic "1" = >3.5Vdc.
- Input burnout to +/-30Vdc without damage.
- Isolation 500Vac, input common to system ground.
- Power requirements: Serial = 0.75W.

D8720 Digital Outputs

- 15 Open-collector outputs to 30Vdc, 100mA max.
- Vsat: +0.3Vdc max. at 100mA.
- Short circuit protection to 500mA.
- Communications Watchdog Timer.
- Digital Output update rate, 4.5Hz.
- Isolation 500Vac, output common to system ground.
- Power requirements: Serial = 1.0W.

Specifications are subject to change without notice.

GENERAL DESCRIPTION

The D8000 series USB interface modules connect to a host computer using a USB interface cable and they communicate using a virtual serial communications port using the Modbus RTU protocol.

Use a USB cable to connect the D8000 to a host computer. Plugging the cable into the computer will create a virtual serial port in the computer. The virtual serial port will be used by the host to communicate with the module. Serial communication ports are supported by almost all data acquisition and process control programs in the marketplace.

The Modbus RTU protocol is used to read and write data values to the D8000 series modules. The Modbus RTU protocol is a serial protocol and communicates with external devices through using serial ports. The Modbus RTU protocol is widely recognized throughout the data acquisition industry and is supported by almost all commercial process control programs.

Multiple D8000 series modules can be connected to one host computer. A unique and separate serial port is created for each module that is connected. The serial port approach provides instant compatibility with almost all industry standard data acquisition programs that support the Modbus RTU protocol.

With the DGH modules, anyone familiar with a personal computer can construct a data acquisition system. This approach to data acquisition is very flexible, easy to use and cost effective. The modules can be mixed and matched to fit your application. You do not need engineering experience in complicated data acquisition hardware to build a system.

ANALOG INPUT MODULES

The D8100 through D8400 series analog input modules contain seven differential analog input channels. Each module contains analog signal conditioning circuits that are optimized for a specific signal input type. Signal types include DC voltage, 4-20mA current loops, and eight thermocouple types. Each input channel can be programmed to accept a different signal input range.

The sensor signals are converted to digital data with a microprocessor-controlled integrating A/D converter. Offset and gain errors in the analog circuitry are continuously monitored and corrected using microprocessor techniques.

The analog input modules communicate the resultant data values as 16-bit unsigned integer numbers that represent a percentage of the full. The modules continuously convert data values at the rate of up to 25 conversions per second and store the latest result in a buffer. The data values are requested by sending a Modbus query to the module. The D8000 series modules will instantly respond by communicating the data values back to the host processor.

ANALOG OUTPUT MODULES

The D8500 analog output modules contain two 12-bit digital to analog converters (DAC) for generating either voltage or current output signals. The output signal type for each DAC is user-selectable and each DAC is independently controlled via a host computer using the Modbus RTU protocol. Four different analog output ranges are available, two voltage ranges and two current ranges.

The D8500 analog output modules contain user-selectable features such as programmable output slew rate, a communications watchdog timer and programmable startup signal value. They also include an 8-bit analog to digital converter for analog readback the output signal.

The communications watchdog timer can be used to move the analog output signal to a known "safe" condition in the event of a communications failure.

DIGITAL INPUT MODULES

The D8710 digital input modules contain 15 individual inputs for monitoring logic levels, contact closures, or other ON/OFF signals in a data acquisition system. Each digital input terminal contains a pull-up biasing resistor allowing for direct connection to a set of contacts. The input terminals can accept signals between +/-30Vdc without damage.

DIGITAL OUTPUT MODULES

The D8720 digital output modules contain 15 individual open-collector transistor outputs for controlling annunciators, lamps, or other devices that require an ON/OFF signal.

The D8720 digital output modules also contain programmable features such as a communications watchdog timer and programmable startup signal values for each bit.

The communications watchdog timer can be used to move the digital output signals to a known "safe" condition in the event of a communications failure.

COMMUNICATIONS

The D8000 series modules are designed to easily interface with computers using a USB interface. The USB interface creates a virtual serial communications port on the host computer. All communications to and from the module, through the virtual serial port are performed using the Modbus RTU protocol. A new serial port is added for each D8000 series module.

MODBUS COMMAND SET

The D8000 series modules use the Modbus RTU protocol for communications. The Modbus RTU binary protocol uses a master-slave technique, in which only the master device can initiate transactions. The slave devices respond by supplying the requested data to the master or by performing the requested action in the query. The master can address any slave device. The returned messages are considered response messages. The supported master function codes are:

Modbus RTU Functions and Descriptions

- 01 – Read Coil Status
- 02 – Read Register Status
- 03 – Read Holding Registers
- 04 – Read Input Register (Analog Inputs)
- 05 – Force Single Coil
- 06 – Preset Single Register
- 0F – Force Multiple Coils
- 10 – Preset Multiple Registers

PROCESS CONTROL SOFTWARE

Modbus RTU protocol is one of the most widely supported serial protocols in the data acquisition market. Modbus RTU software drivers are available for almost every data acquisition software program available today. Thus providing instant connectivity between the D8000 modules and most data acquisition software programs.

SETUP

The D8000 series modules are initialized at the factory using the Modbus RTU protocol. User selectable features such as individual channel range selection and digital filters are easily configured using the DGH setup software. Each D8000 module must be properly configured before installation into a Modbus system.

UTILITY SOFTWARE

Complimentary Utility Software is included with each purchase order. The software is compatible with Windows operating systems and distributed on CDROM.

The Utility Software simplifies configuration of all user selectable options such as device address, baud rate and filtering constants. The latest version of our software is always available on our web site at www.dghcorp.com.

CONTACT INFORMATION

DGH Corporation
P.O. Box 5638
Manchester, NH 03108
Ph: (603) 622-0452
Fax: (603) 622-0487
Email: information@dghcorp.com
Website: <http://www.dghcorp.com/>



ORDERING GUIDE

Voltage Inputs

D8100 7Ch Voltage, Thermocouple/USB

Current Inputs

D8200 7Ch +/-20mA Input/USB

Thermocouple Inputs

D8300 7Ch Thermocouple/RS-485

Voltage, Thermocouple, Current Inputs

D8400 7Ch Voltage, Thermocouple, Current/USB

Voltage and Current Analog Outputs

D8500 2Ch Voltage, Current Analog Output/USB

Digital Inputs/Outputs

D8710 15-Bit Digital Input/USB

D8720 15-Bit Digital Output/USB

MECHANICAL DIMENSIONS

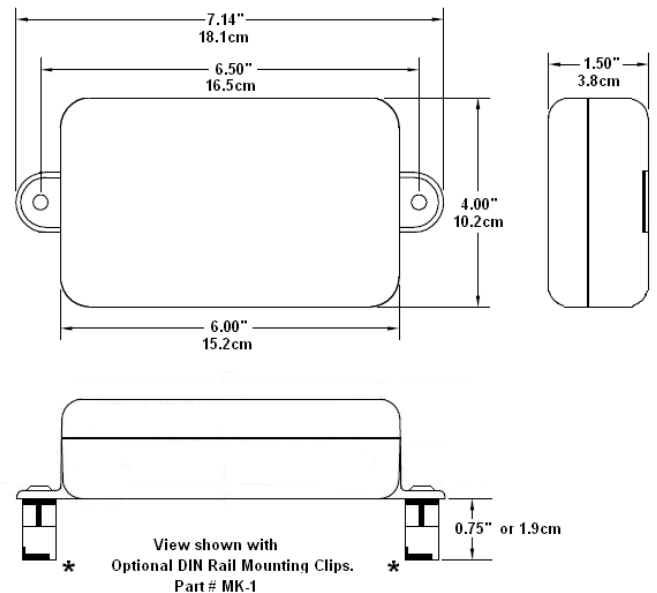

The D8000 series modules can be easily adapted to a DIN rail using the DGH MK-1 mounting kit shown in view above.

STANDARDS AND MARKINGS



Made in USA