

D7000 SERIES MODBUS TCP/IP ETHERNET INTERFACE MODULES



D7000 FEATURES

- Complete data acquisition systems.
- Analog and Digital I/O models available.
- RJ45 Ethernet 10/100MB interface.
- Modbus TCP/IP Protocol.
- Up to 25 conversions per second.
- 500Vrms analog input or analog output isolation.
- 16-bit analog input measurement resolution.
- Continuous self-calibration; no adjustments required.
- Programmable analog input digital filters.
- Requires +10V to +30Vdc unregulated supply.
- Removable screw terminal plug connectors supplied.

APPLICATIONS

- Process monitoring and control
- Remote data logging to any host computer
- Product testing
- Peer-To-Peer communication

GENERAL DESCRIPTION

The D7000 series modules are a family of complete data acquisition modules for use in process control systems. The analog input models can measure process signals such as thermocouples, 4-20mA loops, and discrete contact closures. The analog output models can generate voltage or current signals for controlling annunciators or valves. The digital input and output models can sense the state of remote digital signals or control solid state relays. Complete data acquisition systems can be created with ease with the D7000 modules and a host supervisory computer or programmable logic controller.

The modules provide direct connection to a wide variety of sensors and annunciators. They perform all signal conditioning and linearization and contain no pots or DIP switches. All user-selectable settings, such as ranges, communications settings are stored in nonvolatile EEPROM, which maintains these values even after power is removed.

D7000 SPECIFICATIONS (typical at +25°C and nominal power supply unless otherwise noted)

General

- Programmable digital filters in analog input modules.
- Max CMV, input to output at 115Vrms, 60hz: 500V rms.
- All setups stored in EEPROM.
- Software disable unused analog input channels.

Interface

- Communications via Modbus TCP/IP protocol.
- RJ45 Ethernet 10/100MB Interface.

Power Requirements

- Unregulated +10V to +30Vdc.
- Protected against power supply reversals.

Environmental

- Temperature Range: Operating -25°C to +70°C.
- Storage: -25°C to +85°C.
- Relative Humidity: 0 to 95% non-condensing.

Warranty

- 12 months on workmanship and material.

Package, Dimensions and Connectors

- Case: ABS thermoplastic, UL-94-5VA rated.
- Dimensions: 6"x4"x1.5", mounting holes 6.5" on center.
- Connectors: Screw terminal barrier plug (supplied).
- Replace plug with LMI Components 04238 Series.

MODULE SPECIFICATIONS

D7100 Voltage Inputs

- Seven differential voltage inputs.
- Ranges: +/-0.025V, +/-0.05V, +/-0.1V, ±1V, ±5V, ±10V.
- 16-bit ADC, 25/20 conversions per second.
- Accuracy: ±0.05% of FS max.
- Span Tempco: ±50ppm/°C max.
- Input burnout protection to 250 Vac.
- Input impedance: 20MΩ min.
- Power requirements: Serial = 1.4W.

D7200 Current Inputs

- Seven differential current inputs.
- Range: +/-20mA.
- 16-bit ADC, 25/20 conversions per second.
- Accuracy: ±0.05% of FS max.
- Span Tempco: ±50ppm/°C max.
- Voltage drop: 2.0V max.
- Input Impedance: <100 Ohms (70 typical).
- Power requirements: Serial = 1.4W.

D7300 Thermocouple Inputs

- Seven differential thermocouple inputs.
- Thermocouple types: J, K, T, E, R, S, B, and C.
- Ranges:

J = -200–760°C	R = 0–1750°C
K = -150–1250°C	S = 0–1750°C
T = -200–400°C	B = 0–1820°C
E = -100–1000°C	C = 0–2315°C

D7300 Thermocouple Inputs (cont'd)

- Thermocouple Accuracy (error from all sources) from 0-40°C ambient:
 - J, K, T, E = ±1.5°C max.
 - R, S, B, C = ±3.5°C max (300°C to +F.S.).
- 16-bit ADC, 25/20 conversions per second.
- Input impedance: 20MΩ min.
- Automatic cold junction compensation.
- Lead resistance effect: <40μV per 350Ω.
- Open thermocouple and over range indication.
- Input burnout protection to 250Vac.
- Power requirements: Serial = 1.4W.

D7400 Voltage, Thermocouple, Current Inputs

- Seven Differential voltage, thermocouple, current inputs.
- Specifications equal to D7100, D7200 and D7300 series.

D7500 Analog Outputs

- Two analog outputs.
- Programmable voltage or current ranges.
- Voltage Ranges: 0-10Vdc, +/-10Vdc.
- Current Ranges: 0-20mA, 4-20mA.
- 250 conversions per second.
- Accuracy: +/-0.1%
- 12-bit DAC resolution.
- Span Tempco: ±25ppm/°C max.
- Settling Time to 0.1% FS: 1mS.
- Communications Watchdog Timer.
- Current Output Compliance: +/-12Vdc.
- Voltage Output Drive: 5mA max.
- 8-bit ADC Analog output signal readback.
- Isolation 500Vac, output common to system ground.
- Current output burnout protected to 250Vac.
- Power requirements: Serial = 2.1W.

D7710 Digital Inputs

- 15 Digital Inputs.
- Internal 10K pull-up resistors on each bit.
- Accept direct switch closure.
- Logic "0" = <1Vdc, Logic "1" = >3.5Vdc.
- Input burnout to +/-30Vdc without damage.
- Isolation 500Vac, input common to system ground.
- Power requirements: Serial = 0.75W.

D7720 Digital Outputs

- 15 Open-collector outputs to 30Vdc, 100mA max.
- Vsat: +0.3Vdc max. at 100mA.
- Short circuit protection to 500mA.
- Communications Watchdog Timer.
- Digital Output update rate, 4.5Hz.
- Isolation 500Vac, output common to system ground.
- Power requirements: Serial = 1.0W.

D7730 Digital Inputs/Outputs

- 7 Inputs, 8 outputs to 30Vdc, 100mA max.
- Outputs, Vsat: +0.3Vdc max. at 100mA.
- Short circuit protection to 500mA.
- Communications Watchdog Timer.
- Digital Output update rate, 4.5Hz.
- Isolation 500Vac, output common to system ground.
- Power requirements: Serial = 1.0W.

All D7000 specifications are subject to change without notice.

GENERAL DESCRIPTION (Continued)

The D7000 series modules communicate with a host computer using the Modbus TCP/IP protocol. The Modbus TCP/IP protocol is widely recognized throughout the data acquisition industry and supported by almost all commercially available process control programs and supervisory host computers and PLC's.

The key to the DGH product concept is that the modules are easy to connect and use. You do not need engineering experience in complicated data acquisition hardware. With the DGH modules, anyone familiar with a personal computer can construct a data acquisition system. This modular approach to data acquisition is very flexible, easy to use and cost effective. The modules can be mixed and matched to fit your application. They can be placed remote from the host and from each other.

ANALOG INPUT MODULES

The D7100 through D7400 series analog input modules contain seven input channels and makeup a complete data acquisition system. Each unit contains analog signal conditioning circuits optimized for a specific input type. The amplified sensor signals are converted to digital data with a microprocessor-controlled integrating A/D converter. Offset and gain errors in the analog circuitry are continuously monitored and corrected using microprocessor techniques.

The analog input modules output the resultant digital data as unsigned integer percentage of full-scale values that are compatible with the Modbus RTU protocol. The modules continuously convert data at the rate of up to 25 conversions per second and store the latest result in a buffer. Host processors may request data by sending a Modbus query to the module. The D7000 series modules will instantly respond by communicating the memory buffer data back to the host processor.

ANALOG OUTPUT MODULES

The D7500 analog output modules contain two 12-bit digital to analog converters (DAC) for generating either voltage or current output signals. The output signal type for each DAC is user selectable and each DAC is independently controlled via a host computer using the Modbus RTU protocol. Two voltage and two current ranges are available.

The D7500 analog output modules also contain programmable features such as output slew rate, a communications watchdog timer, programmable startup signal value, and an 8-bit analog to digital converter for analog read back the output signal.

The communications watchdog timer can be used to move the analog output signal to a known "safe" condition in the event of a communications failure.

DIGITAL INPUT MODULES

The D7710 digital input modules contain fifteen individual signal inputs for monitoring logic levels, contact closures, or other ON/OFF signals in a data acquisition system. Each discrete input terminal contains a pull-up biasing resistor allowing for direct connection to a set of contacts. The input terminals can accept signals between +/-30Vdc without damage.

DIGITAL OUTPUT MODULES

The D7720 digital output modules contain fifteen individual open-collector transistor outputs for controlling annunciators, lamps, or other devices that require an ON/OFF signal.

The digital output modules also contain programmable features such as a communications watchdog timer and programmable startup signal values for each bit.

The communications watchdog timer can be used to move the digital output signals to a known "safe" condition in the event of a communications failure.

DIGITAL INPUT/OUTPUT MODULES

The D7730 combination digital input/output module contains eight digital inputs and seven open-collector digital outputs. The digital outputs can be used to control annunciators, lamps, or other devices that require an ON/OFF signal. The digital inputs can be used for sensing contact closures

The module also contains a programmable communications watchdog timer and user-programmable startup signal values for each digital output.

The communications watchdog timer can be used to move the digital output signals to a known "safe" condition in the event of a communications failure.

COMMUNICATIONS

The D7000 series modules are designed to easily interface with Ethernet networks. All communications to and from the module are performed using the Modbus TCP/IP protocol via an RJ45 Ethernet interface.

MODBUS COMMAND SET

The D7000 series modules use the Modbus TCP/IP protocol for communications. The Modbus TCP/IP binary protocol uses a master-slave technique, in which only the master device can initiate transactions. The slave devices respond by supplying the requested data to the master or by performing the requested action in the query. The master can address any slave device. The returned messages are considered response messages. The supported master function codes are:

Modbus TCP/IP Functions and Descriptions

- 01 – Read Coil Status
- 02 – Read Register Status
- 03 – Read Holding Registers
- 04 – Read Input Register (Analog Inputs)
- 05 – Force Single Coil
- 06 – Preset Single Register
- 0F – Force Multiple Coils
- 10 – Preset Multiple Registers

PROCESS CONTROL SOFTWARE

Modbus TCP/IP protocol is one of the most widely supported serial protocols in the data acquisition market. Modbus TCP/IP software drivers are available for almost every data acquisition software program available today. Thus providing instant connectivity between the D7000 modules and most data acquisition software programs.

SETUP

The D7000 series are initiated at the factory using the Modbus TCP/IP protocol. Features such as the Modbus device address, baud rate, and analog signal ranges can be easily configured using the DGH setup software. Each D7000 module must be properly configured before installation into a Modbus system.

UTILITY SOFTWARE

Complimentary Utility Software is included with each purchase order. The software is compatible with Windows operating systems and distributed on CDROM.

The Utility Software simplifies configuration of all user selectable options such as device address, baud rate and filtering constants. The latest version of our software is always available on our web site at www.dghcorp.com.

CONTACT INFORMATION

DGH Corporation
P.O. Box 5638
Manchester, NH 03108
Ph: (603) 622-0452
Fax: (603) 622-0487
Eml: information@dghcorp.com
Web: <http://www.dghcorp.com/>



ORDERING GUIDE

Voltage Inputs

D7100 7Ch Voltage, Thermocouple/Ethernet Interface

Current Inputs

D7200 7Ch +/-20mA Input/ Ethernet Interface

Thermocouple Inputs

D7300 7Ch Thermocouple/ Ethernet Interface

Voltage, Thermocouple, Current Inputs

D7400 7Ch Voltage, Thermocouple, Current/Ethernet Interface

Voltage and Current Analog Outputs

D7500 2Ch Voltage, Current Analog Output/Ethernet Interface

Digital Inputs/Outputs

D7710 15-Bit Digital Input/Ethernet Interface

D7720 15-Bit Digital Output/Ethernet Interface

D7730 7-Digital Inputs, 8-Digital Outputs/Ethernet Interface

MECHANICAL DIMENSIONS

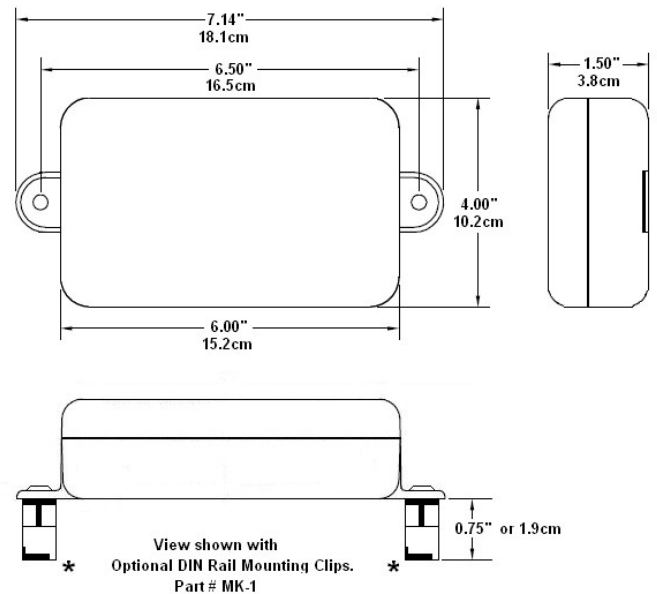

The D7000 series modules can be easily adapted to a DIN rail using the DGH MK-1 mounting kit shown in view above.

STANDARDS AND MARKINGS



Made in USA